



Engineering Brochure

**T-Model Cooling Towers
A Manufacturer for 42 Years**

MEMBER



196 Lower Cherry Street
Macon, GA 31201
800-752-1905
478-755-1905
800-203-4925 FAX
478-755-8304 FAX

www.coolingtowersystems.com
info@coolingtowersystems.com



The Cooling Tower Systems Tower

Design Features:

The non-rusting FRP casing and basin, circular in shape, eliminates special installation requirements. Prevailing wind directions will not affect tower performance.

Casing:

Easy access through casing simplifies cleaning. Individual fiberglass panels are stainless steel bolted together for periodic wash down and general clean up. The CTS FRP cooling tower is designed for durability and long life even under the most severe environmental weather conditions.

Fan Blades:

Aerodynamically designed propeller type fan blades are used to conserve power and assure quiet operations. CTS models T-25 through T-230 feature a factory-balanced ABS plastic blade. CTS models T-240 and above feature an all aluminum alloy adjustable fan.

Fan Drive:

CTS models T-25 through T-2200 have direct drive fan motors. CTS models T-2225 and larger feature a unique belt drive, designed to reduce noise levels, with optional gear drives.

Water Distribution System:

CTS models T-25 through T-260 use an ABS plastic sprinkler with stainless steel shaft. CTS models T-270 and above use an aluminum alloy sprinkler head. Both types of sprinkler head require little or no head pressure loss and minimum maintenance.

Inlet Louvers:

Non-rusting PVC plastic mesh provides easy access to sump while preventing foreign objects from entering water basin.

Ladder:

Provided for maintenance and inspection accessibility to fan and sprinkler systems. (Models T-240 and above.)

Fill Material:

Honeycomb heat-embossed PVC is formed to permit high heat transfer efficiency. The CTS fill is suitable for operation with inlet water temperatures of 125° F. For higher temperatures, contact your representative for quote.

Engineered for Cost Efficiency & High Performance

The fan motor is weatherproofed and totally enclosed allowing for less noisy and more efficient long-term performance.

Housing panels and water basin are built of fiberglass-reinforced plastic ensuring rust-free long-term performance even under the most severe environmental conditions.

The sprinkler pipes are sturdy PVC material pierced with closely spaced holes allowing thorough distribution of water in a rotating spray covering the entire surface of the filler.

The efficiently designed PVC filler creates a surface area that allows for maximum dispersion of water and creates a superior cooling effect.

The round design permits maximum air intake regardless of wind direction.

A large-capacity, durable water basin constructed from rustproof fiberglass reinforced plastic guarantees low maintenance and long-term operation.

Efficient operation results from the smooth pumping of re-circulated water through the stand pipe and up into the sprinkler pipes.

A large diameter outlet pipe draws a constant supply of cooled water from the basin to serve the facility.

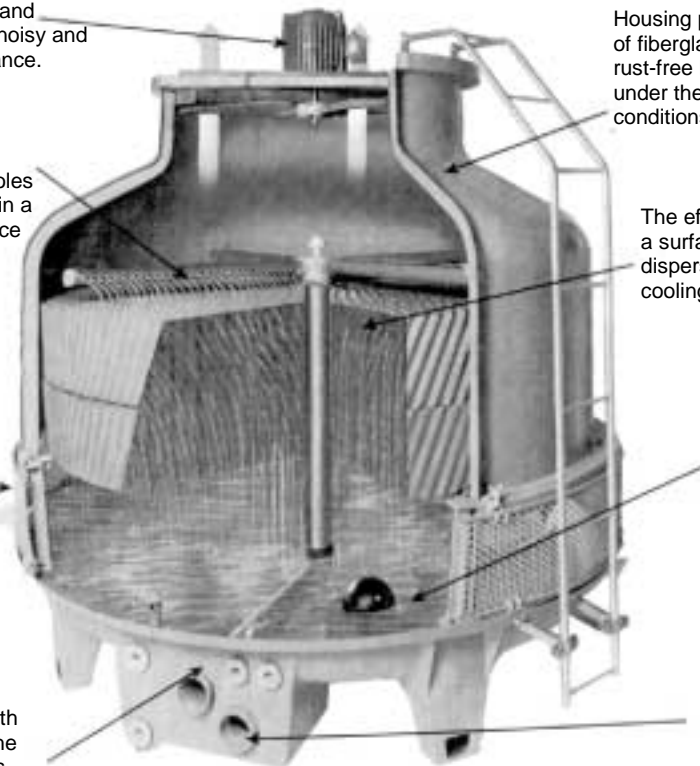

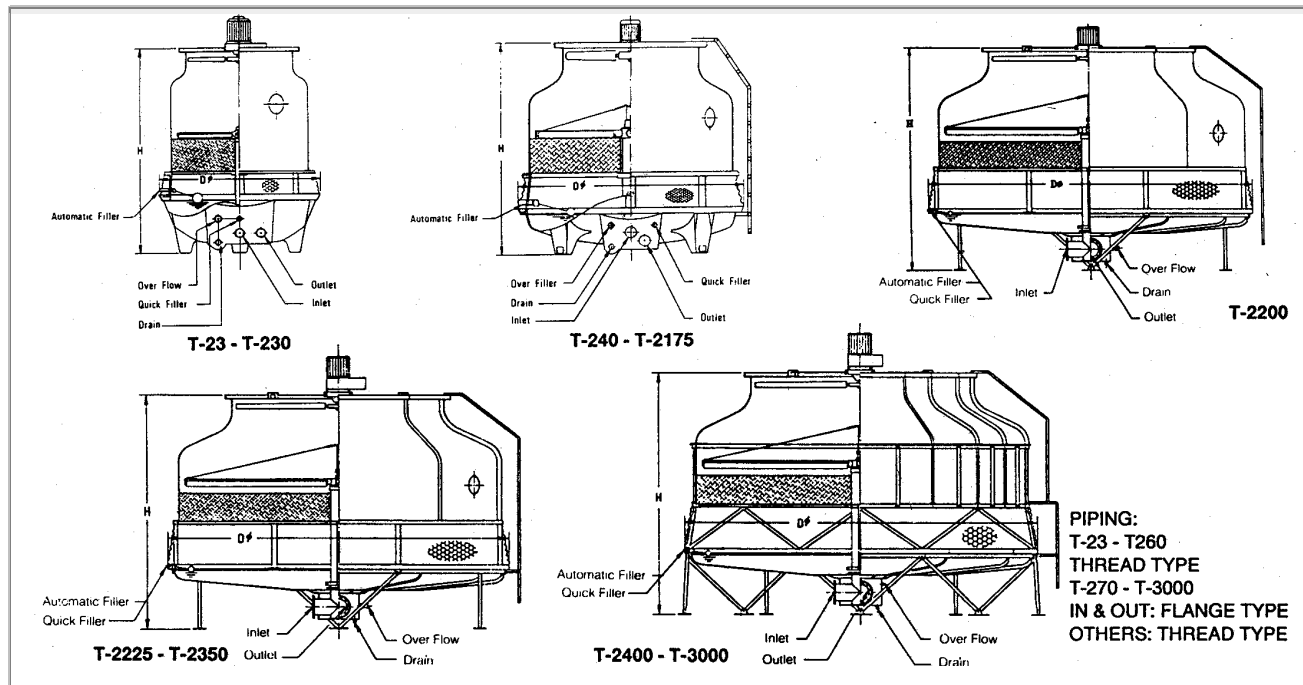

T MODEL	DIMENSIONS (IN.)		PIPE CONNECTIONS (IN.)						FAN MOTOR (HP)	FAN DIAMETER (INCH)	AIR VOLUME (CFM)	NOMINAL WATER FLOW (GPM)
	HEIGHT	DIA.	IN	OUT	O	Dr	FLOAT	Q				
T-25	52	33 1/2	1 1/2	1 1/2	1	3/4	1/2	-	1/6 *	19 1/2	2118	15
T-28	56	33 1/2	1 1/2	1 1/2	1	3/4	1/2	-	1/6 *	19 1/2	2648	23
T-210	54	41 3/4	1 1/2	1 1/2	1	3/4	1/2	-	1/4 *	26 3/8	3531	30
T-215	59	46	2	2	1	1	1/2	-	1/4 *	26 3/8	4767	44
T-220	63	54 3/8	2	2	1	1	1/2	-	1/2 **	30 1/4	6356	58
T-225	70 15/16	54 3/8	2 1/2	2 1/2	1	1	1/2	-	3/4 ***	30 1/4	7000	73
T-230	68 3/8	62 1/4	2 1/2	2 1/2	1	1	1/2	-	1 ***	30 1/4	8100	88
T-240	74 1/2	71 5/8	2 1/2	2 1/2	1	1	3/4	-	1 1/2 ***	38 1/4	9800	118
T-250	74 1/2	78 3/4	3	3	1	1	3/4	-	1 1/2 ***	38 1/4	11500	148
T-260	74 11/16	78 3/4	3	3	1	1	3/4	-	1 1/2 ***	46	14700	177
T-270	79 3/8	85 5/8	4	4	1	1	3/4	-	1 1/2 ***	46	17500	207
T-280	79 3/8	85 5/8	4	4	1	1	3/4	-	2 ***	46	18900	237
T-2100	85 1/16	104 3/8	4	4	1	1	1	-	3 ***	57 7/8	24500	295
T-2125	87	120 1/8	6	6	2	1	1	-	3 ***	57 7/8	29060	369
T-2150	90	130	6	6	2	2	1	-	5 ***	68 7/8	33260	446
T-2175	97 7/8	130	5	5	2	2	1	-	5 ***	68 7/8	40250	518
T-2200	117 3/4	148 3/8	6	6	2	2	1 1/4	1 1/4	5 ***	68 7/8	43760	592
T-2225	125 5/8	148 3/8	6	6	2	2	1 1/4	1 1/4	7 1/2 ***	93	61270	656
T-2250	125 5/8	148 3/8	8	8	2	2	1 1/4	1 1/4	7 1/2 ***	93	61270	737
T-2300	131 7/8	174 3/4	8	8	2	2	1 1/4	1 1/4	10 ***	93	77020	883
T-2350	133 1/2	188 5/8	8	8	2	2	1 1/4	1 1/4	10 ***	93	77020	1036
T-2400	153 1/8	203 7/8	8	8	4	2	2	2	15 ***	117	91030	1190
T-2500	154 11/16	219 5/8	10	10	4	2	2	2	15 ***	117	91030	1505
T-2600	171 5/8	259 7/8	10	10	4	2	2	2	20 ***	133 1/8	125000	1777
T-2700	181 5/16	259 7/8	10	10	4	2	2	2	20 ***	133 1/8	125000	2101
T-2800	194 11/16	299 1/4	12	12	4	3	2	2	30 ***	141	175000	2370
T-3000	202 1/2	299 1/4	12	12	4	3	2	2	30 ***	141	175000	3011

Electrical specifications: *110/220/1/60, 220/3/60, ** 110/220/1/60, 220/440/3/60, ***220/440/3/60
 Tri-voltage fan motors (208-230-460-3-60) are available for 3/4 h.p. and larger. Special order 50 cycle fan motors also available.
 Nominal flow is defined as rate of water cooled from 95° to 85°, with 75° wet bulb temperature.

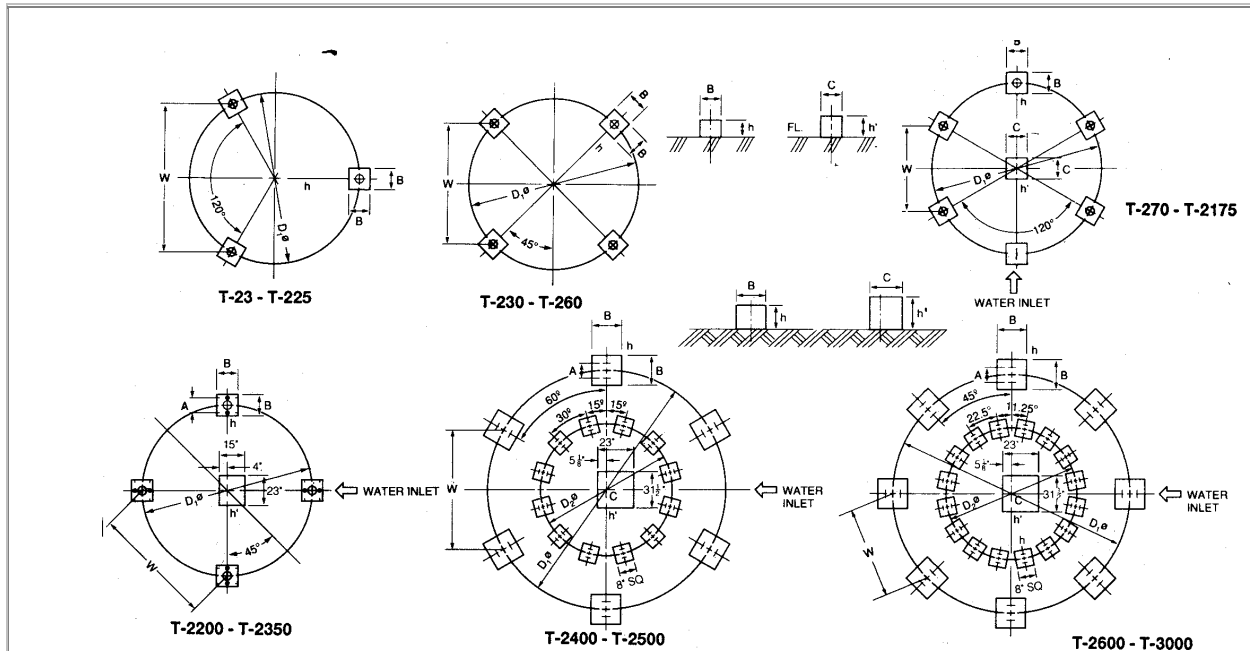

T MODEL	WEIGHT (LBS.)		DIMENSIONS (IN.)							ANCHOR BOLT		QTY (PCS.)	PUMP HEAD (FT.)	
	DRY	OPERATING	D1	W	B	A	h	h'	C	D2	SIZE (INCH)			LENGTH (INCH)
T-25	86	251	21 5/8	18 3/4	8		6				1/2	4 3/4	3	5.0
T-28	93	262	21 5/8	18 3/4	8		6				1/2	4 3/4	3	5.0
T-210	123	443	29 1/2	25 5/8	8		6				1/2	4 3/4	3	5.0
T-215	139	536	34 5/8	30	8		6				1/2	4 3/4	3	5.3
T-220	190	719	44	38 1/4	8		6				1/2	4 3/4	3	5.6
T-225	227	887	44	38 1/4	8		6				1/2	4 3/4	3	5.6
T-230	253	1074	52 1/2	37	8		6				1/2	4 3/4	4	6.0
T-240	369	1133	57 7/8	40 7/8	10		8				1/2	4 3/4	4	6.6
T-250	435	1313	66 1/8	46 3/4	10		8				1/2	4 3/4	4	6.6
T-260	504	1472	66 1/8	46 3/4	10		8				1/2	4 3/4	4	6.6
T-270	610	1555	69 3/8	34 1/2	10		8	9 1/2	10		1/2	4 3/4	5	6.6
T-280	642	1588	69 3/8	34 1/2	10		8	9 1/2	10		1/2	4 3/4	5	6.6
T-2100	887	2361	92 1/2	46 1/4	12		12	14	12		5/8	8	5	8.2
T-2125	1025	2983	103 1/8	51 1/2	12		12	14	12		5/8	8	5	10.0
T-2150	1375	5731	112 1/2	56 1/4	12		12	13 1/2	16		5/8	8	5	10.0
T-2175	1569	5887	112 1/2	56 1/4	12		12	13 1/2	16		5/8	8	5	11.0
T-2200	1914	7612	132	93 3/8	12	5 1/8	12	16	23		5/8	8	8	11.0
T-2225	2112	7744	132	93 3/8	12	5 1/8	12	16	23		5/8	8	8	11.0
T-2250	2266	7854	132	93 3/8	12	5 1/8	12	16	23		5/8	8	8	12.0
T-2300	2823	9995	156 1/8	110 3/8	12	5 1/2	12	16	23		5/8	8	8	12.0
T-2350	2996	10164	169 1/8	119 5/8	12	5 1/2	12	16	23		5/8	8	8	13.2
T-2400	4776	14984	200 3/4	100 3/8	20	5 1/2	12	16	31 1/2	114 1/4	3/4	8	12	13.2
T-2500	5342	15550	216 1/2	108 1/4	20	5 1/2	12	16	31 1/2	122	3/4	8	12	13.2
T-2600	7401	23637	255 1/8	97 5/8	20	5 1/2	12	16	31 1/2	141 3/4	3/4	8	16	16.4
T-2700	7848	24127	255 1/8	97 5/8	20	5 1/2	12	16	31 1/2	141 3/4	3/4	8	16	18.2
T-2800	9636	26356	295 1/4	113	20	5 1/2	12	16	31 1/2	163 1/2	3/4	8	16	20.0
T-3000	10199	27359	295 1/4	113	20	5 1/2	12	16	31 1/2	163 1/2	3/4	8	16	20.0

Specifications subject to change without notice.

SOUND PRESSURE LEVELS OF COOLING TOWER SYSTEMS TOWERS

LEVEL OF MEASUREMENT: db

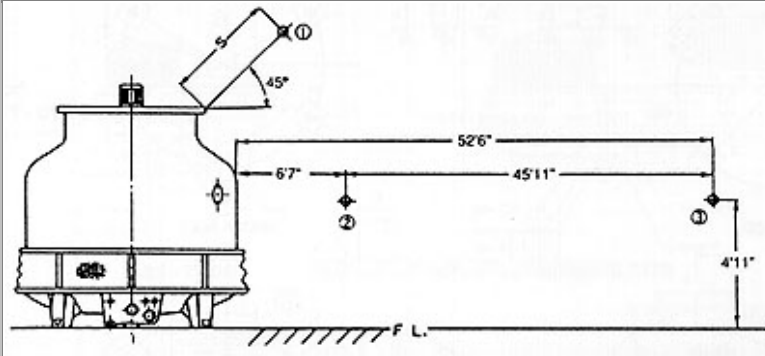

NOTE: THE ACCURACY OF MEASURING VALUE IS ± 3 DECIBELS

REMARKS:

- POINT 1 IS 45° EXTENSION OF FAN DISCHARGE.
- DISTANCE "S":
 (1) T MODELS 2125 & LOWER - 4'11"
 (2) T MODELS 2150 & ABOVE - FAN DIAMETER

TOWER MODEL	T-25			T-28			T-210			T-215			T-220			T-225			T-230		
MEASURING PT.	1	2	3	1	2	3	1	2	3	1	2	3	1	2	3	1	2	3	1	2	3
SCALE A	62	59	48	63	58	47.5	64	59	48.5	69	66	53	69	66	53	70	67	57	73	67	59
TOWER MODEL	T-240			T-250			T-260			T-270			T-280			T-2100			T-2125		
MEASURING PT.	1	2	3	1	2	3	1	2	3	1	2	3	1	2	3	1	2	3	1	2	3
SCALE A	77	70	59	77	70	59	79	73	64	81	75	66	82	76	67	79	71	60	84	74	64
TOWER MODEL	T-2150			T-2175			T-2200			T-2225			T-2250			T-2300			T-2350		
MEASURING PT.	1	2	3	1	2	3	1	2	3	1	2	3	1	2	3	1	2	3	1	2	3
SCALE A	77	71	62	80	75	65	79	73	63	76	71	62	76	71	62	77	72	63	77	72	63
TOWER MODEL	T-2400			T-2500			T-2600			T-2700			T-2800			T-3000					
MEASURING PT.	1	2	3	1	2	3	1	2	3	1	2	3	1	2	3	1	2	3	1	2	3
SCALE A	79.5	74.5	65.5	79.5	74.5	65.5	77.5	72.5	63.5	77.5	72.5	63.5	78.5	74	65	80	75	66			

TOWER CAPACITIES

HOT WATER	90 ° F	90 ° F	95 ° F	92 ° F	95 ° F	97 ° F	95 ° F	95 ° F	96 ° F	98 ° F	90 ° F	94 ° F	T MODEL
COLD WATER	80 ° F	80 ° F	85 ° F	82 ° F	85 ° F	87 ° F	85 ° F	85 ° F	86 ° F	88 ° F	83 ° F	85 ° F	
WET BULB	65 ° F	70 ° F	70 ° F	72 ° F	75 ° F	75 ° F	77 ° F	78 ° F	80 ° F	82 ° F	75 ° F	75 ° F	
GPM	17	12	20	13	15	18	12	11	10	11	15	16	T-25
	27	20	32	21	23	29	20	18	16	17	25	26	T-28
	34	25	39	27	30	35	25	23	20	23	31	32	T-210
	51	37	60	40	44	54	37	33	31	33	46	48	T-215
	68	49	80	53	58	72	49	45	41	44	62	64	T-220
	85	62	97	66	73	90	62	56	52	56	77	79	T-225
	101	75	119	80	88	108	75	68	63	68	93	96	T-230
	134	100	156	106	118	142	101	92	85	91	124	128	T-240
	168	127	195	134	148	178	127	116	108	115	155	159	T-250
	201	150	224	160	177	211	151	138	128	137	185	191	T-260
	236	176	262	188	207	251	176	160	150	160	218	224	T-270
	268	203	308	215	237	253	203	185	173	184	248	256	T-280
	335	250	382	266	295	356	252	230	213	228	309	319	T-2100
	420	316	480	235	369	446	316	289	270	289	388	400	T-2125
	504	383	574	405	446	534	383	353	328	350	466	479	T-2150
	588	441	676	471	518	611	444	407	377	404	541	558	T-2175
	669	509	774	542	592	712	512	469	440	469	621	640	T-2200
	757	559	885	595	656	803	559	503	468	503	696	717	T-2225
	838	625	970	666	737	889	630	574	533	569	772	798	T-2250
	1011	775	1175	800	883	1075	755	685	634	678	934	960	T-2300
1176	889	1340	946	1036	1240	895	818	767	818	1087	1119	T-2350	
1349	1023	1540	1084	1190	1420	1023	930	871	932	1240	1278	T-2400	
1657	1301	1885	1377	1505	1763	1324	1226	1157	1233	1551	1604	T-2500	
2006	1526	2322	1625	1777	2137	1537	1406	1319	1406	1864	1919	T-2600	
2317	1819	2640	1928	2101	2469	1841	1700	1641	1711	2177	2242	T-2700	
2675	2035	3096	2166	2370	2849	2050	1875	1759	1875	2486	2559	T-2800	
3303	2616	3760	2762	3011	3300	2660	2484	2353	2499	3098	3201	T-3000	

NOTE: TONS OF REFRIGERATION AT 250 BTU/MIN WITH 3GPM/TON.